

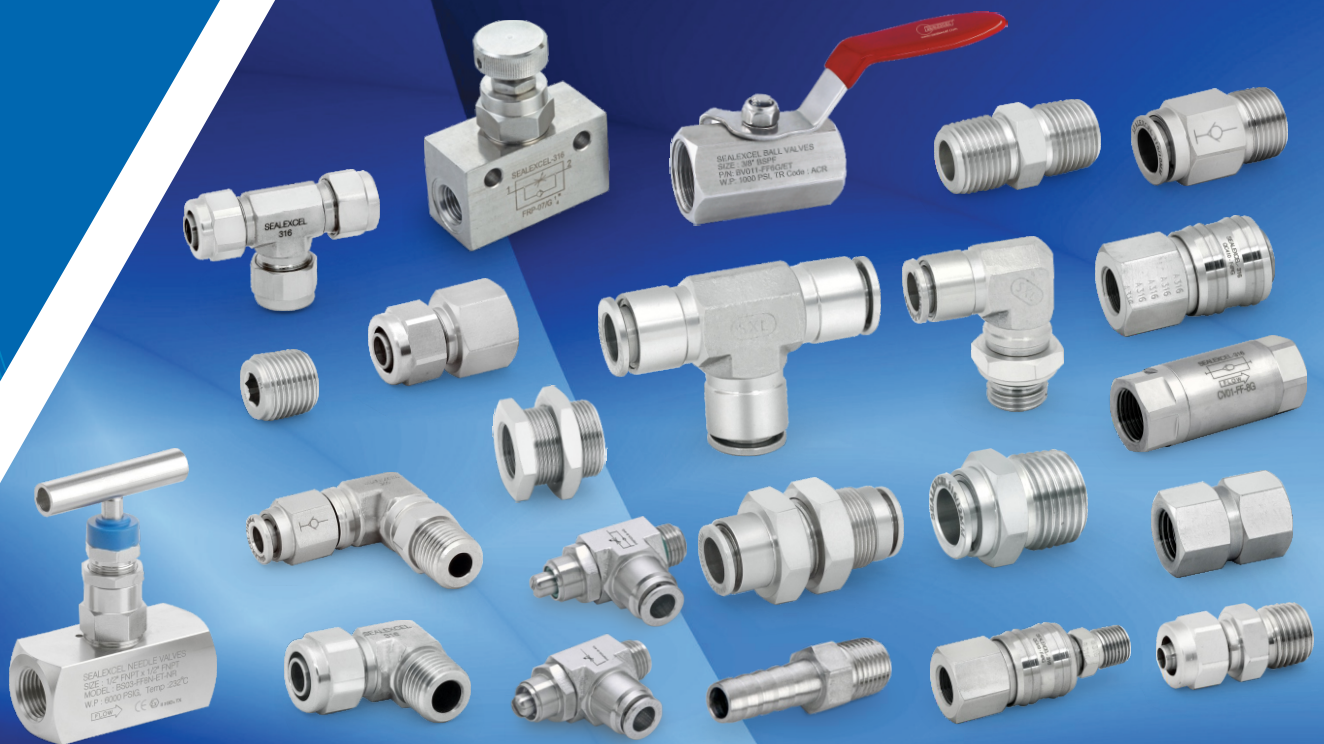

Cost Effective, Best Quality Stainless Steel Fittings & Valves for Pneumatic Applications



Automation Specially by Pneumatic is rapidly increasing in the process of Industrial growth and transformation. Considering the growing demand for Stainless Steel Pneumatic products in aggressive environments and corrosive fluids.

SEALEXCEL® has designed, developed and manufactured Stainless Steel Fittings and Valves to meet the requirement of Pneumatic Applications compliant to FDA. These products are most suitable in aggressive and corrosive environments which are generally used in chemicals, Food, Packaging, Printing Industries etc.



STAINLESS STEEL PUSH-IN-FITTINGS

SERIES - PIF

SEALEXCEL® Stainless Steel Push-in-Fittings consist of six precision components such as Body, Releasing Sleeve, Lock Ring, Gripping Collet, Guide Rings and 'O' Rings. These components have been carefully designed and manufactured to meet the high quality requirements in Pneumatic Applications.

These Fittings are Resistance to Aggressive Environments and Fluids, which are generally used in Chemicals, Food & Packaging Industries etc.



FEATURES

- Available in material SS316L
- 'O' Ring Sealing : Food Grade Viton®
- Compliant to FDA
- Compact and attractive design
- Reliable leak tight sealing system
- Easy for Manual connection and dis-connection
- No tools required for connection and dis-connection
- Full Flow without pressure drop
- Automatic tube sealing with 'O'Ring and locking with gripping collect
- Available with NPT, BSPT, BSPP and SAE Straight thread pipe connections
- Available Metric Size : 4mm to 16mm Tube OD
Fractional Size : 3/16" to 5/8" Tube OD

OPERATING PARAMETERS

Pressure Rating : upto 225 PSI at CWP

Temperature Rating : upto 150°C

MATERIAL OF CONSTRUCTION

Body, Guide Ring : SS 316L

Lock Ring, Releasing Sleeve : SS 316L

Gripping Collet : SS 301

'O' Ring : Food Grade Viton®

Note : EPDM 'O' Rings are available on request.

COMPATIBLE WITH TUBE

- Semi rigid Nylon
- Flexible Polyurethane
- Low density Polyurethane
- Fluoropolymer FEP - 140
- Stainless Steel and copper Tube (with groove)

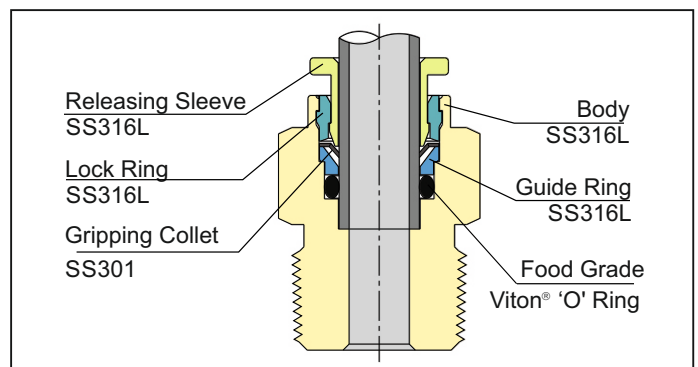

We have obtained NSF certificate for our pneumatic fittings i.e stainless steel push in fittings, stainless steel push on fittings, check valves, quick connect coupling, quick exhaust valves, flow control regulators.

APPLICATION

- Pneumatic Control
- Air Supply to pneumatic machine
- Automatic devices
- Laboratories (Medical, Pharmaceutical etc.)
- Instrumentations

See SEALEXCEL® Catalogue No. PN-1122 for full details.

STAINLESS STEEL PUSH-ON-FITTINGS SERIES - PNO



FEATURES

- Available in material SS316L
- 'O' Ring Sealing : Food Grade Viton®
- Compliant to FDA
- Reliable leak tight sealing system
- Full Flow without pressure drop
- Tube sealing and locking by tightening the nut
- Available with NPT, BSPT, BSPP and SAE Straight thread pipe connections
- Available Metric Size : 6mm to 12mm Tube OD
Fractional Size : 1/4" to 1/2" Tube OD

OPERATING PARAMETERS

Pressure Rating : upto 225 PSI at CWP
Temperature Rating : upto 180°C

COMPATIBLE WITH TUBE

- Polyethylene (PE)
- PTFE
- Fluoropolymer
- Polyurethane (PU)

See SEALEXCEL® Catalogue No. PN-1122 for full details.

APPLICATION

- Pneumatic Control
- Air Supply to pneumatic machine
- Automatic devices
- Laboratories (Medical, Pharmaceutical etc.)
- Instrumentations

QUICK CONNECT COUPLINGS Series-310

FEATURES

- Available in material SS316L
- 'O' Ring Sealing : Food Grade Viton®
- Compliant to FDA
- Robust in construction.
- Easy for manual connection and disconnection.
- No tools required for connection and disconnection.
- Reliable leak tight Sealing System.
- Durable pin-locking mechanism assures reliable connection.
- Valve guide positively aligns valve with seat to prevent leakage.
- Available with nominal flow passage size 2.5mm, 5mm, and 7.5mm

OPERATING PARAMETERS

Available Size : 1/8" to 1/2" Pipe thread
Pressure Rating : Up to 290 PSI at CWP
Temperature Rating : Up to 120°C
End Connections : Available with Male/Female NPT/BSP/BSPT Pipe Threads



See SEALEXCEL® Catalogue No. PN-1122 for full details.

FLOW CONTROL REGULATORS

These Regulators are use to control the speed of a Pneumatic Cylinder or the speed of Food Fluid carried in aggressive environments or to high mechanical or chemical constraints.

- Available in material SS316L with Viton® 'O' Ring Compliant to FDA



MODEL: FRP03 (One way adjustment) & FRP05 (Bi-Directional)

OPERATING PARAMETERS

Available Size : 1/8" to 1/2" Pipe Thread
 Pressure Rating : Up to 10 Bar at CWP
 Temperature Rating : Up to 120°C
 End Connections : BSP/BSPT/NPT/SAE Straight Thread



MODEL: FRP07 (One way adjustment)

OPERATING PARAMETERS

Available Size : 1/8" to 1/2" Pipe Thread
 Pressure Rating : Up to 16 Bar at CWP
 Temperature Rating : Up to 120°C
 End Connections : BSP/BSPT/NPT/SAE Straight Thread



MODEL: FRP09 (Bi-Directional)

OPERATING PARAMETERS

Available Size : 1/8" to 1/2" Pipe Thread
 Pressure Rating : Up to 40 Bar at CWP
 Temperature Rating : Up to 120°C
 End Connections : BSP/BSPT/NPT/SAE Straight Thread

QUICK EXHAUST VALVES

These valves allows direct exhaust of compressed Air due to increase of cylinder rod displacement speed, this result in reduction of cycle time.

- Available in material SS316L with Viton® 'O' Ring Compliant to FDA

OPERATING PARAMETERS

Available Size : 1/8" to 1/2" Pipe Thread
 Pressure Rating : Up to 10 Bar at CWP
 Temperature Rating : Up to 120°C
 End Connections : BSP/BSPT/NPT/SAE Straight Thread

SEALING MATERIALS : Viton®



See SEALEXCEL® Catalogue No. PN-1122 for full details.

PRECISION PIPE FITTINGS

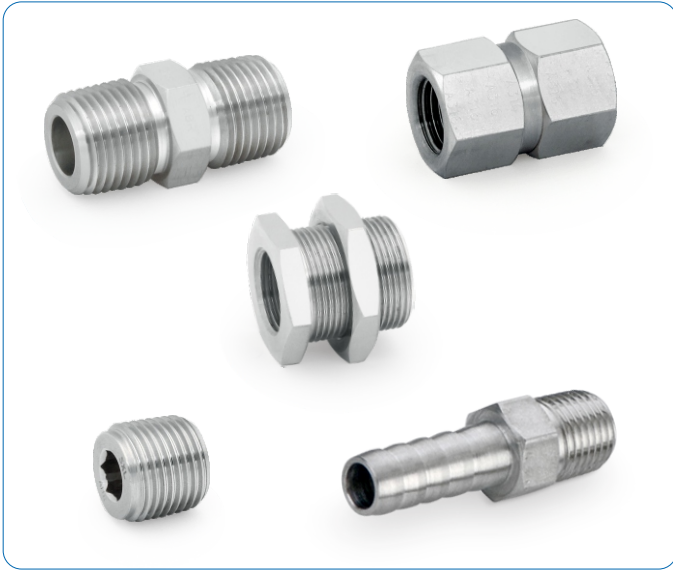

FEATURES

- Available in material SS316L
- Compliant to FDA
- Material Traceable to certified material test report
- Variety of end connections and configurations
- Positive leak-free seal
- Precision thread construction to maximum tolerances to have maximum thread engagement which ensure leak-free, robust and safe connection.
- Available Size : 1/8" to 1" pipe thread
- End Connections : BSP/BSPT/NPT pipe thread

OPERATING PARAMETERS

Pressure Rating : upto 3000 psig (Depending on size)
 Temperature Rating : upto 428°C

See SEALEXCEL® Catalogue No. PN-1122 for full details.

CHECK VALVES SERIES-CV01

SEALEXCEL® Stainless Steel Check Valves Series-CV01 Valves are of Compact and Precise in Design to Provide Single Direction Flow for low pressure application

SEALEXCEL® Stainless Steel Check Valves shut the fluid passage when the Pressure difference is **below 0.25 Bar**.

- Available in material SS316L
- 'O' Ring Sealing : Food Grade Viton®
- Compliant to FDA

OPERATING PARAMETERS

Pressure Rating : 0.5 to 40 Bar at CWP
 Temperature Rating : Up to 180°C
 Available Size : 1/8" to 1/2" BSP/BSPT/NPT Pipe Thread
 Metric Size : 4mm to 10mm Tube OD
 Fractional Size : 3/16" to 3/8" Tube OD



See SEALEXCEL® Catalogue No. PN-1122 for full details.

NEEDLE VALVES SERIES - BS03



FEATURES

- Available in material SS316L
- Heat Code Traceable to certified material test report
- Compliant to FDA
- Low operating torques
- Bar stock Body in Straight Patterns
- Anti Blow-out stem, Variety of stem tips
- PTFE packing standard
- Flow coefficient (Cv) From 0.35 to 1.8
- Orifice size : 0.156" (4.0 mm), 0.250" (6.4mm), 0.375" (9.5mm)
- SEALEXCEL® Well-Lok™ Tube Fittings, Male / Female NPT, BSPT, BSPP pipe and tube socket weld connections
- Available Metric Size : 6mm to 25mm Tube OD
Fractional Size : 1/4" to 1" Tube OD
- Pipe Thread : 1/4" to 1" Pipe Connection

APPLICATION

- General Plant Service
- Instrument Isolation
- Hydraulic and Pneumatic
- Pressure measurement devices
- Venting

OPERATING PARAMETERS

Pressure Rating : upto 6000 psig (408 bar) at CWP
 Temperature Rating : -54°C to 232°C with standard PTFE packing
 upto 426°C with optional Graphite packing

See SEALEXCEL® Catalogue No. PN-1122 for full details.

BALL VALVES SERIES - BV011

FEATURES

- Available in Material SS316L
- Material Traceable to certified material test report
- Compliant to FDA
- One piece Hexagon body design, Bi-directional Flow
- PTFE Ball Seat, Bubble tight shut-off
- Anti blow-out stem, Low torque operation
- Floating ball design provides seat wear compensation
- Quarter turn positive stop handle
- Available Size : 1/4" to 1" Female NPT, BSPP, BSPT Pipe Connections

OPERATING PARAMETERS

Pressure Rating : Upto 1000 psig (69 bar) at CWP
 with PTFE packing seat
 Temperature Rating : -45°C to 232°C with PTFE packing
 and seat



APPLICATION

- Instrument Air Lines
- General Plant Service
- Low Pressure Instrument Lines

See SEALEXCEL® Catalogue No. PN-1122 for full details.

STAINLESS STEEL THREE WAY BALL VALVES

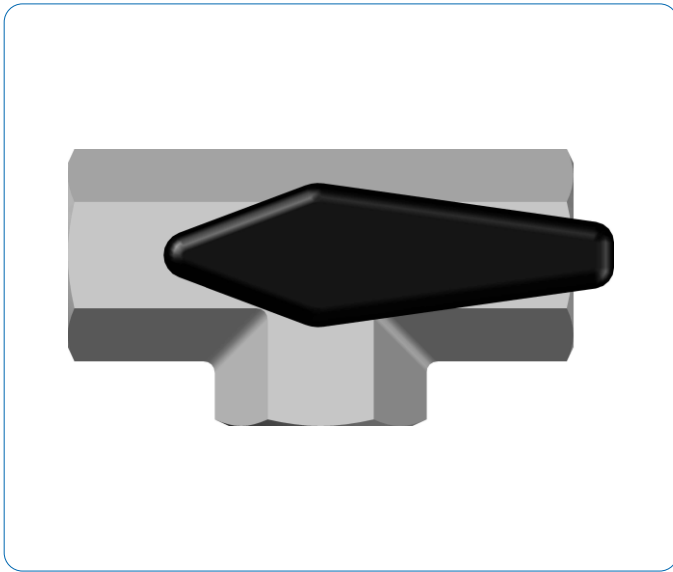

FEATURES

- Available in material SS316L
- 'O' Ring Sealing : Food Grade Viton®
- Compliant to FDA.
- Three way compact Floating Ball design.
- Spring loaded PTFE Seat ensure bubble light sealing and compensate for wear and extend the life of the valves.
- Low torque operation.
- Positive handle stop.

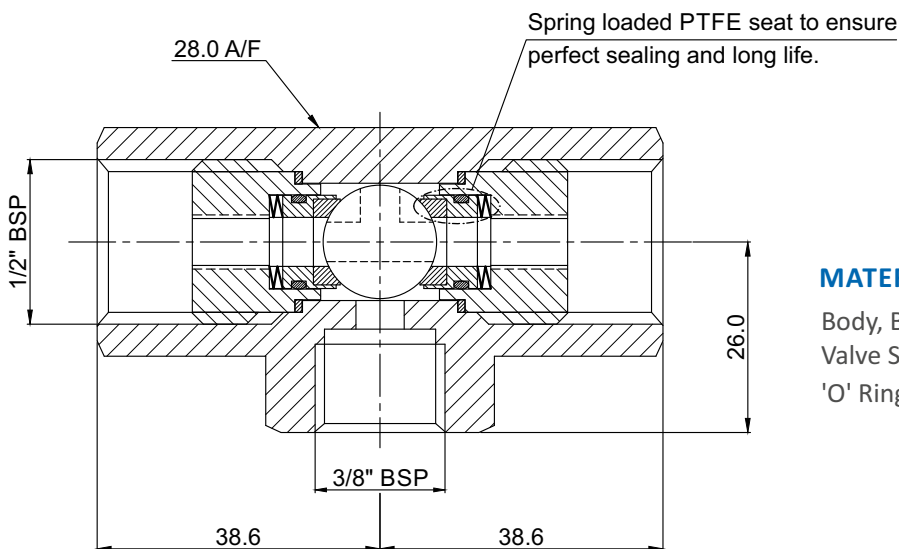

MATERIAL OF CONSTRUCTION.

Body, Ball and Valve components : SS316L
 Valve Seat : PTFE
 'O' Ring : Food Grade Viton®

ORDERING PART NO. : 3BV013-8-6RG/ETV

OPERATING PARAMETERS

Pressure Rating : Upto 1000 psig (69 bar) at CWP with PTFE packing seat
 Temperature Rating : Up to 180°C with PTFE packing, seat and Food Grade Viton® O-Ring.

APPLICATION

- Beverage Machine

SEALEXCEL Broad range of Precision Instrumentation products

 <p>Twin/Single Ferrule Tube Fittings</p>	 <p>37° Flare Tube Fittings To SAE J514</p>	 <p>Instrument Threaded & Welded Pipe Fittings</p>	 <p>Tube Fittings With Integral Flange</p>	 <p>Low /Medium Pressure Ball Valves</p>
 <p>High Pressure Ball Valve</p>	 <p>High Pressure 2/3 Ball Valve</p>	 <p>Needle Valve</p>	 <p>Needle Valves (Panel Mountable)</p>	 <p>High Pressure Needle Valve</p>
 <p>Rising Stem Plug Valves</p>	 <p>Gauge/Root Valves</p>	 <p>Instrument 2/3/5 Manifold Valves</p>	 <p>Monoflange Valves</p>	 <p>Single / Double Block & Bleed Valves</p>
 <p>Purge Valves</p>	 <p>Bleed Valves</p>	 <p>Toggle Valves</p>	 <p>Relief Valves</p>	 <p>Check Valves</p>
 <p>Micron In-line Filters</p>	 <p>Quick Connect Couplings</p>	 <p>Stainless Steel Pneumatics Fittings & Valves</p>		

NOTES

The secret of our success is our engineering expertise, best quality products, timely delivery and prompt communications



SEALEXCEL has over three decades of experience in Design, Development and Manufacturing Consistent and reliable quality Fittings and Valves which have built a great deal of trust based on our World Class advanced technology and cutting edge machineries.

We believe it is our mission to always supply products of highest quality and catering to the regular requirements of our customers in India as well as Australia, Europe, middle East, South Africa, USA etc.



Manufacturing Facilities



Computerised Micro Hardness Tester

We have two well-equipped modern manufacturing facilities in India, we manufacture all our products in our own manufacturing facilities under strict quality assurance procedures approved to ISO 9001:2015. We also have in-house product performance testing facilities to

check and verify the maximum safety and reliability of our products.

SEALEXCEL's total quality management from incoming raw material inspection through ongoing quality check during production with sophisticated checking Instrument, final inspection, assembly, testing, packing and despatch ensure highest quality products and has earned us various quality certifications for pneumatic products.

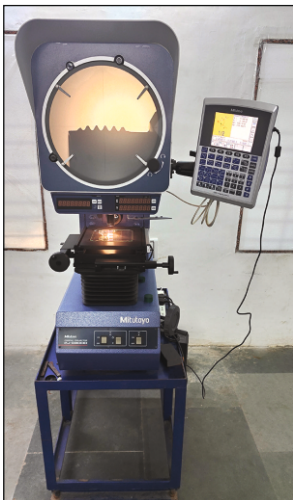

Precision Profile Projector



ISO 9001:2015

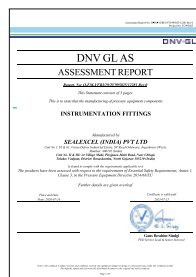

PED 2014/68/EU

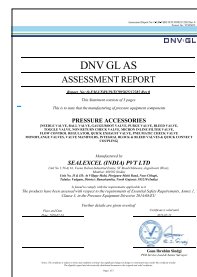

PED 2014/68/EU



ISO 22000:2005



FDA

We strive for Total Customer Satisfaction and continuously work to set of goals to provide the best quality and delivery of products and services in the best interest of our customers at competitive price.

For more information, please contact our sales department at sales@sealexcel.com



SEALEXCEL[®] (INDIA) PVT. LTD.

Regd. Office & Unit-I : 56 & 61, Veena Dalvai Industrial Estate,
S. V. Road, Oshiwara, Jogeshwari (west), Mumbai - 400 102. India.
Phone : +91-22-26786885, 26788534, 66944124
Fax : +91-22-26781426, 66944126
E-mail : sales@sealexcel.com, Website : <https://www.sealexcel.com>

Unit II : At Post - Mahi, Pirojpora - Mahi Road,
Via Chhapi, Taluka-vadgam, Dist-Banaskantha,
North-Gujarat, Pin-385210. India